



Telescopic
Vertical
Axis



Vertical Axis
Balance
Cylinder



Manual
Central
Lubrication



Easy Position
(Location)
Teaching



Fast
Cycle

► FUNDAMENTAL MECHANICAL SPECIFICATIONS

Model	Axis Strokes (mm)			Injection Clamping Force Range (Ton)	Driving Method	Lineer Position Repeatability (mm)	C Axis Posture ↘ 90°		Net Weight (kg)
	Vertical	Crosswise	Traverse				Maximum Payload (kg)	C Axis Posture Torque (Nm)	Main Body
SCH1200II	1200	680	1800	250 - 400	AC Servo Motor	±0.1	10 (*1)	65	670

(*1) Weight of Robotic Hand is Included.

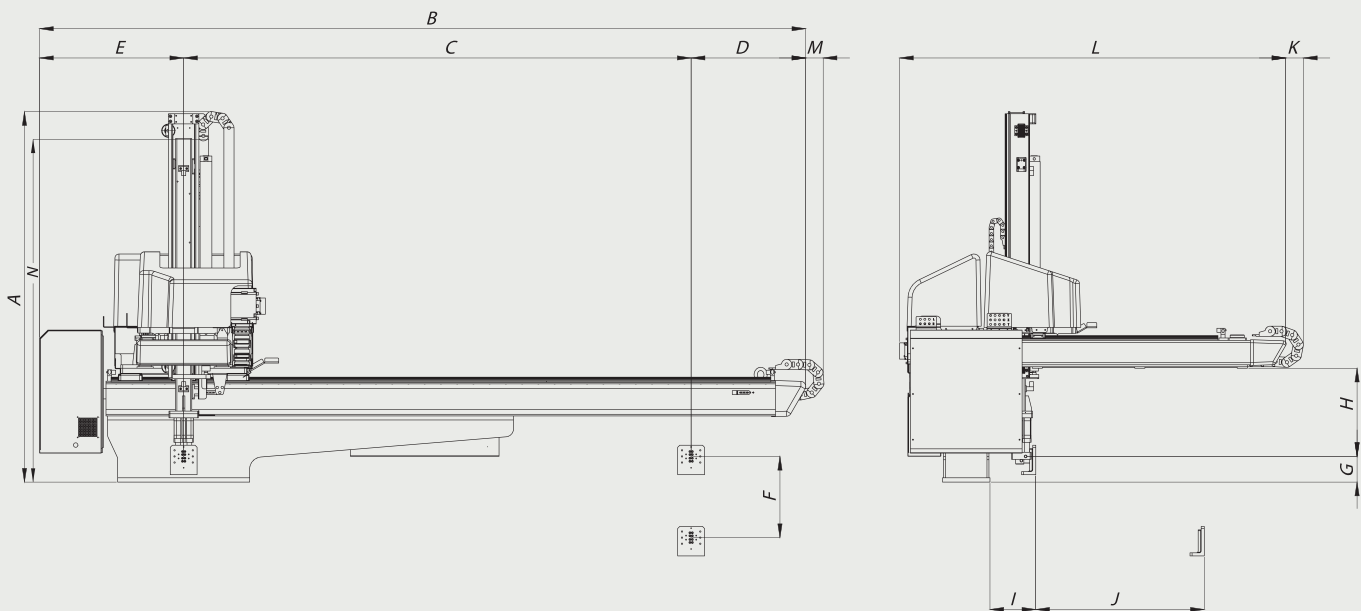

DIMENSIONS (mm)

A	Height	1675
B	Length	3025
C	Traverse Axis Stroke	1800
D	Traverse Axis Stroke Excluded Distance (Product Place Region)	520
E	Traverse Axis Stroke Excluded Distance (Product Pick Up Region)	710
F	Vertical Axis Stroke	1200
M	Traverse Axis Cable Carrier Overflow	230
N	Balance Cylinder Height	1410

G	Vertical Wait	118
H	Gripper Assembly Position under Crosswise Axis	440
I	Minimum Crosswise Wait	256
J	Maximum Crosswise Stroke	680
I+J	Maximum Crosswise Reach	936
L	Width	1685
K	Crosswise Start Distance	160

Power Supply	Maximum Power (kW)	Air Pressure (Bar)	Air Consumption (NI/Cycle)
Three-phase AC 380V ± %10 (50Hz/60 Hz)	4.3	4 - 6	3.5

(*2) Need for Pressurized Air Purified (Dried) from Oil and Humidity Exists.

GENERAL FEATURES

- Vacuum Line
- Blow Line
- Sprue Gripper Line
- Product Pickup from Fixed and Moving Platens
- Selection of Operator / Non-operator Working Direction
- Vacuum Level Adjustment on the Control Panel
- Product Sorting and Stacking
- Product Sorting in Matrix Form
- Soft Sorting / Separation
- Y Axis Free
- Eco Mode (Automatic Energy Saving Cycle Feature)
- Product Extraction from Core in the Mold
- Sprue Separation
- Sample Separation
- Crosswise J (Pass) Motion
- Defective Product Separation (Machine Feature Compatibility Support)
- Message Support on the Control Panel
- IMM Door Open Permission during Pause
- Pause during Operation
- C Axis Rotation Control
- 90° Soft Stop
- Connection Adapter between Robot and Injection Machine
- Mode Operation Function Control
- Extra Mold Safety Sensor (Optional)
- Overload Protection
- Conveyor Control
- Multi Language Support
- Operation Record Feature
- Alarm Record Feature
- USB Memory Connection
- Memory of upto 999 Molds
- Ejector Control
- Euromap 12/67 Robot Interface
- Economic Vacuum Feature (Optional)